

AWON 



FLAIL MOWERS | STANDARD

FM

User Manual

**100-120-140-160
165-185-205
180-200-220-240
260-280-300**

Introduction	4
Safety	
1.1 Safety Signs and Symbols	6
1.2 Safety Instructions and Recommendations.....	10
Operation Instructions	
2.1 Lifting and Transportation.....	14
2.2 Tractor Attachment.....	15
2.3 Driveline Adjustment.....	18
2.4 Blade Operation	22
2.5 Cutting Height Adjustment	26
2.6 Mulching Operation.....	28
Maintenance Instructions	
3.1 Belt Replacement.....	31
3.2 Troubleshooting.....	32
3.3 Routine Maintenance	33
3.4 Maintenance Recommendations	34
Specifications	
4.1 Technical Specifications	36
4.2 PTO Selection Table.....	38
4.3 Three-point Linkage Specifications.....	39
EC Declaration of Conformity	40

Dear Customer,

Thank you for purchasing a product manufactured by AWON Machinery. To help you use this product safely and correctly while maximizing its value, we kindly ask you to read this manual carefully and keep it for future reference. Proper operation and routine maintenance will extend the service life of the equipment, prevent damage, and reduce the risk of personal injury.

To ensure the best experience, we kindly request your cooperation with the following:

- ✓ Operate and maintain the product in accordance with the specified guidelines.
- ✓ Ensure that all relevant users read this manual and fully understand the correct procedures for installation, operation, and maintenance.
- ✓ Confirm that the equipment is properly prepared and adjusted before use, and regularly verify that its settings are correct.

In preparing this user manual, we have made every effort to ensure its accuracy and completeness, striving to avoid errors and omissions. At AWON Machinery, we are continuously working to optimize and improve our products and services. If you have any suggestions or require further information, please contact us by phone at +31 (0)416 447 898 10 or via email at info@awonmachinery.com.

PRODUCT STANDARDS

EN ISO 12100:2010, EN ISO 4254-12:2012, EN ISO 4413:2010

CE Marking

The CE marking is typically located on the front of the product. It provides unique identification for each unit and serves as a reference for the main specifications and characteristics of the equipment, including:

AWON machinery		CE	① Awon Europe B.V. Professor Lorentzweg 16 5144 NP Waalwijk THE NETHERLANDS info@awonmachinery.com	
Model:				②
Serial No.:				③
Year of Manufacture:				④
Weight:				⑤
				KG
	HP ⑥	PTO ⑦	FLOW ⑧	PRESSURE ⑨
				ROTOR ⑩
				www.awonmachinery.com

- | | | |
|-------------------------|--------------------------------|-----------------------|
| 1. Manufacturer address | 5. Weight | 8. Hydraulic flow |
| 2. Model | 6. Required tractor horsepower | 9. Hydraulic pressure |
| 3. Serial number | 7. PTO speed | 10. Rotor speed |
| 4. Year of manufacture | | |



The CE marking must remain attached to the product throughout its entire lifecycle, including during sale, maintenance, repair, and until the product is decommissioned or scrapped.

1.1 Safety Signs and Symbols

Timely identification of problems or hazardous situations, together with appropriate measures, can effectively prevent accidents.

Please read this operating manual carefully, familiarize yourself with the relevant controls and correct operating procedures, and understand emergency handling methods in case of incorrect operation. This will enable you to quickly identify the cause of faults, resolve them promptly, and resume safe operation.

The safety symbols used in this manual indicate three levels of hazard:

 NOTICE	Indicates a situation where failure to follow instructions may result in damage to the machine or equipment.
 WARNING	Indicates a potentially hazardous situation which, if not avoided, may result in injury.
 DANGER	Indicates a hazardous situation which, if not avoided, could result in serious injury or death to the operator or others.

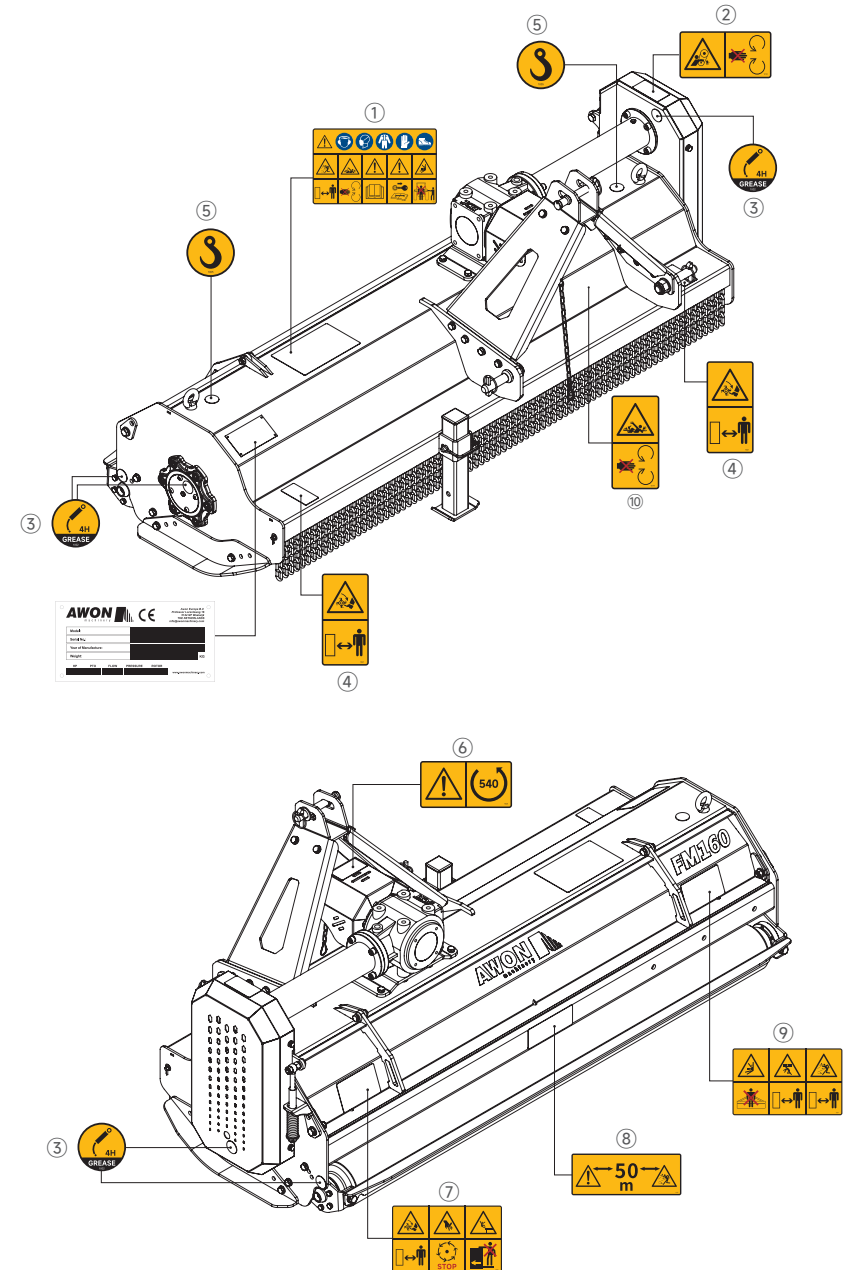

This section explains the locations and meanings of the safety labels. Familiarize yourself with these labels to ensure safe and proper use. If any labels are damaged, replace them promptly. Contact your dealer to obtain replacement labels and reattach them in their original positions.



①

- Always wear appropriate personal protective equipment (PPE), including hearing protection, respiratory protection, protective clothing, protective gloves, and safety shoes.
- Keep a safe distance from the machine during operation to avoid injury from thrown objects.
- To prevent entanglement hazards from the PTO shaft and other rotating parts, stay clear of the machine and all rotating parts during operation.
- Attention! Read operator's (user) manual.
- WARNING! Before carrying out maintenance, adjustment, or repair, stop the machine, switch off the engine, remove the key, apply the parking brake, and refer to the operating manual.
- Stay clear of the machine during operation to avoid being struck by moving parts or thrown objects.



②

- Keep a safe distance from the machine during operation. Risk of entanglement in the belt drive.
- Keep hands away from moving parts. Contact can result in serious injury. Do not remove the belt pulley guard while the engine is running.



③

- Grease every 4 hours.



④

- Keep feet away from moving parts. Contact can result in serious injury.
- Keep a safe distance from the machine during operation to avoid injury from thrown objects.



⑤

- Lifting point – use only for lifting the machine.



⑥

- WARNING! PTO speed: 540 rpm



⑦

- Keep feet away from moving parts. Keep a safe distance from the machine during operation to avoid injury from thrown objects.
- Do not touch the blades until all moving parts have stopped. Contact can result in serious injury.
- Do not stand on the machine during operation. Risk of falling and serious injury.



⑧

- Keep a minimum distance of 50 m from the machine during operation. Thrown objects can cause serious injury.



⑨

- Do not stand behind the machine during operation. Risk of being struck by moving parts or thrown objects.
- Keep a safe distance from the machine. Crushing hazard.
- Keep a safe distance from the machine to avoid injury from thrown objects.



⑩

- Keep hands and body away from moving parts. Risk of entanglement and serious injury.

1.2 Safety Instructions and Recommendations

Before operating the mulcher, the following checks must be carried out:

1. Ensure that all fasteners are properly tightened and that all locking pins are correctly installed and secured.
2. Ensure that all protective devices, such as guards or safety chains, are properly installed and securely fastened.
3. Ensure that all blades are securely installed. If the machine has been previously used, check the blades for excessive wear, cracks, or deformation. Replace the blades if necessary.
4. Since the center of gravity of the tractor may shift after installing the machine, it is recommended to add front ballast weights to the tractor to ensure proper balance and safe operation.

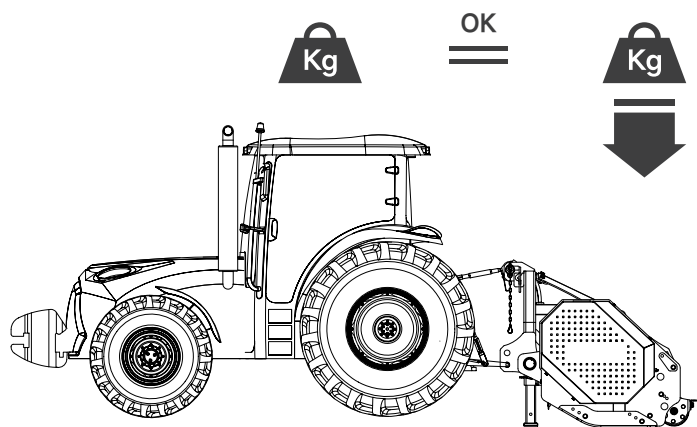

Tractor Counterweight

Installing the mulcher on the tractor will change the tractor's center of gravity. Therefore, it is recommended to install additional ballast weights at the front of the tractor to maintain proper balance and ensure safe operation.

The required ballast weight can be calculated using the following parameters:

$$Z \geq \frac{M \times S - 0.2 \times T \times i}{d + i}$$

Where:
 $S = S1 + S2$ and $M < 0.3 \times T$

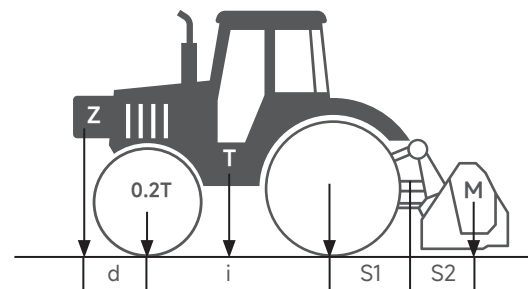

i	Tractor wheelbase (cm)
d	Distance from the front axle to the ballast weight (cm)
T	Total weight of the tractor including operator (kg)
Z	Ballast weight (kg)
M	Mulcher weight (kg)
S	Horizontal distance from the mulcher center of gravity to the rear axle (cm)
S1	Distance from the rear axle to the center point of the three-point linkage (cm)
S2	Distance from the lower linkage hitch point to the mulcher center of gravity (cm)

When operating the mulcher, observe the following instructions:

1. Ensure that the PTO shaft is securely connected to the mulcher before lifting the machine.
2. Begin operation at a low forward speed and check whether the cutting height is appropriate. If the cutting height is too deep or too shallow, stop the mulcher and adjust the cutting height as described in Section 2.6 "Cutting Height Adjustment".
3. Do not make sharp turns or reverse suddenly while the mulcher is in operation.
4. Keep all persons away from the PTO shaft and the machine when the driveline is engaged.
5. Start the PTO shaft and ensure that the operating speed does not exceed 540 rpm.

After completing operation, perform the following steps:

1. Move the machine to a flat and open area. Slowly lower the mulcher to the ground and adjust the support stand until it rests securely on the ground.
2. Release the PTO safety chain and disconnect the PTO shaft.
3. Remove the three-point linkage by disconnecting the linkage pins and locking pins in sequence. Store the pins on the mulcher for future use.

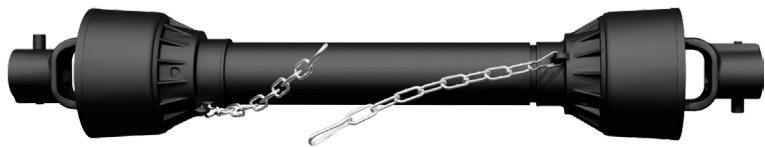
**Before lifting the mulcher, perform the following instructions:**

Before lifting the machine, refer to the section 4 "Specifications" for information on the machine weight and dimensions. Use only the designated lifting points marked with the "Lifting point" symbol. Ensure that the lifting equipment used is suitable for the working load and operating conditions. Overloading the lifting equipment is strictly prohibited.



WARNING

Ensure that all moving parts are secured before lifting the machine. Always use lifting equipment with sufficient lifting capacity. Lift and move the machine slowly and carefully. Avoid sudden movements or abrupt stops, as this may result in injury or equipment damage.



DANGER

Lifting and transportation operations must be performed with extreme caution. Improper handling may result in serious injury or equipment damage. Keep unauthorized persons away from the operating area. Ensure that the machine does not collide with other objects during lifting and transportation.



1. Perform lifting operations only in a safe and open area free of obstacles. Ensure sufficient clearance and escape space is available.
2. Always place the machine on a level and stable surface.
3. Secure the machine properly during transportation. Remove securing devices only after ensuring the machine is stable and safe.

2.1 Lifting and Transportation

Lifting

The lifting eyes integrated into the FM series flail mowers are intended exclusively for vertical lifting during transportation and installation. They are made of high-strength steel and are welded or fixed to reinforced sections of the machine frame. The lifting eyes are dimensioned based on the total weight of the machine including a 25% safety margin.

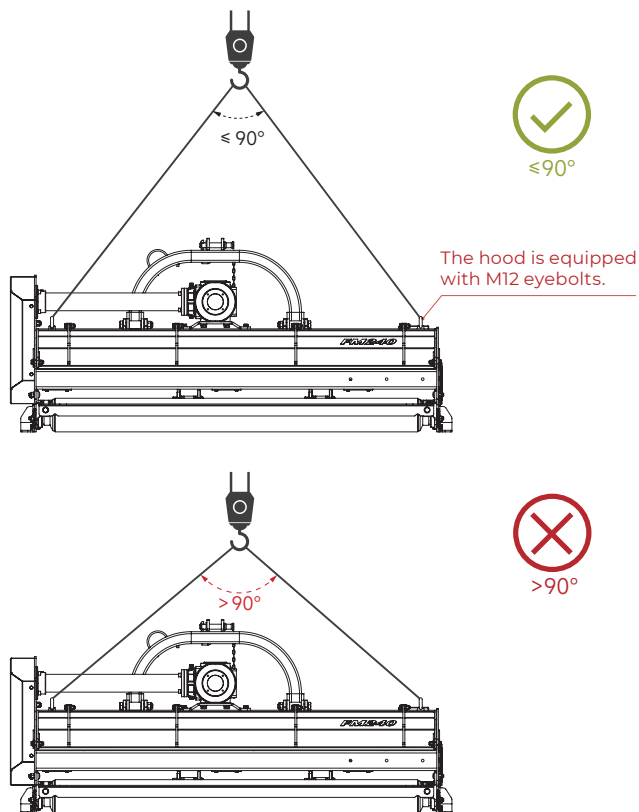

Transportation



Disconnect the PTO shaft before transporting the machine. Never allow persons on the machine during transportation.

WARNING

2.2 Tractor Attachment

Tractor Power

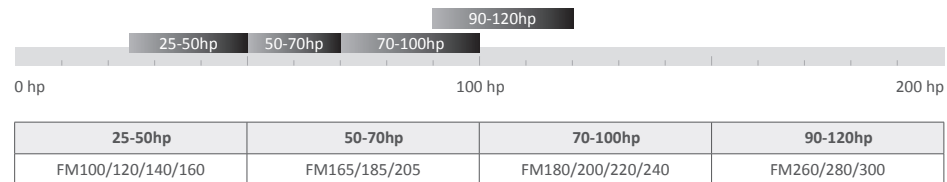

PTO Speed

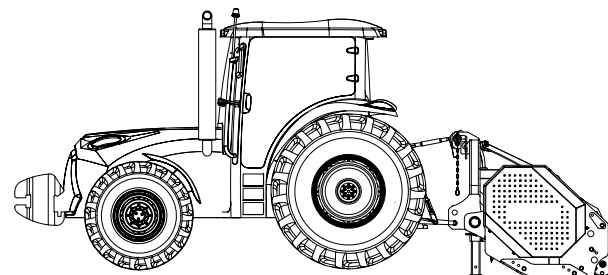
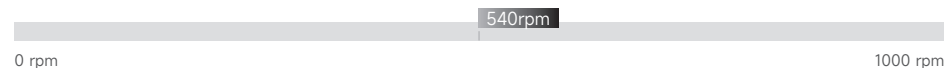

- Use only a tractor with sufficient power, as specified in the Technical Specifications.
- Ensure that the three-point linkage arms are properly secured and stabilized to prevent side-to-side movement of the machine.

Attach the machine to the tractor on a level, stable surface.

Hitch Frame and Main Body Assembly

Install the hitch swing arm in the mounting holes shown below. Secure it with the hitch pin and tighten the lock nuts securely. (See Figs. 1 and 2).

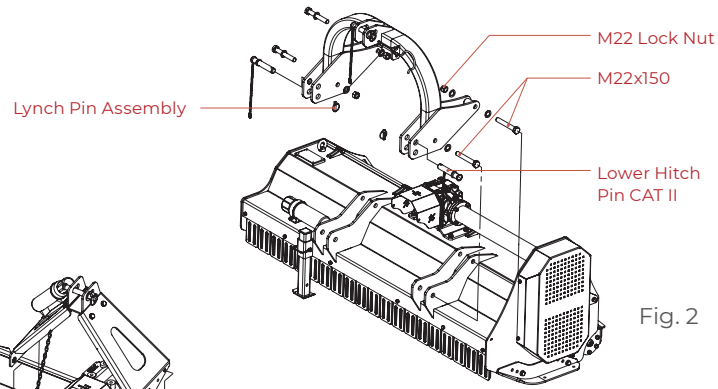

Fig. 2

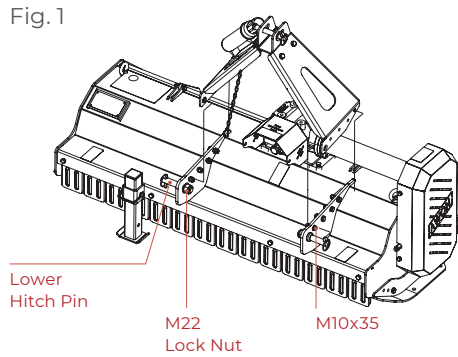
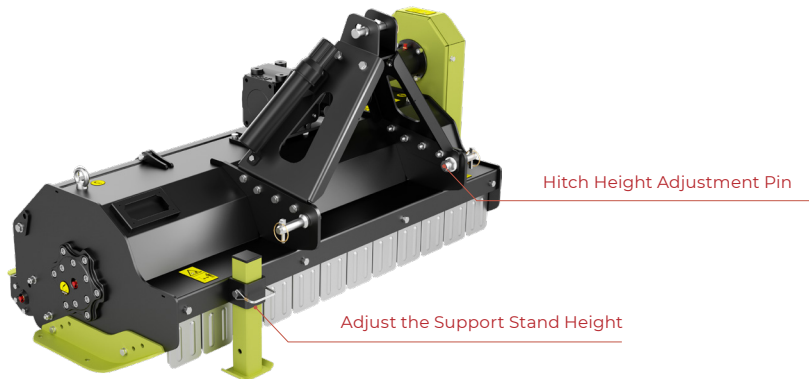

Fig. 1

Attach the machine to the tractor on a level, stable surface. The machine must be attached to the tractor's three-point linkage. Follow the steps below:

1. Adjust the support stand height so that the mower stands upright and stable on the ground.
2. Move the tractor front (or rear) linkage close to the mower hitch.
3. Align the tractor three-point linkage arms with the three hitch points on the mower and connect them correctly.

Fig. 3



4. The hitch height has three adjustment positions. Select the appropriate position, insert the hitch pins, and secure them with lynch pins. (See Fig. 3)
5. Fix the upper hitch point in the same manner.
6. Adjust the tractor linkage turnbuckle to keep the mower level during operation.

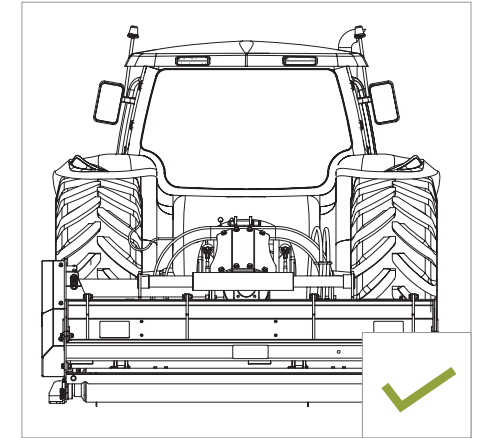
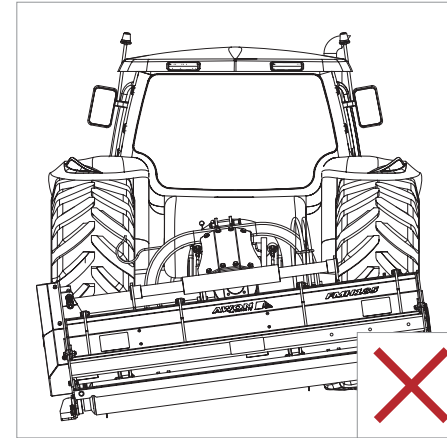

Lateral Balance

7. Connect the PTO shaft between the tractor and the mower gearbox. Ensure that the connection is securely locked.
8. Park the tractor on level ground and slowly raise the mower. When adjusting the length of the top link, it is recommended to tilt the front of the mower slightly upward by about 3–5° to prevent grass and debris from accumulating on the skid plates.

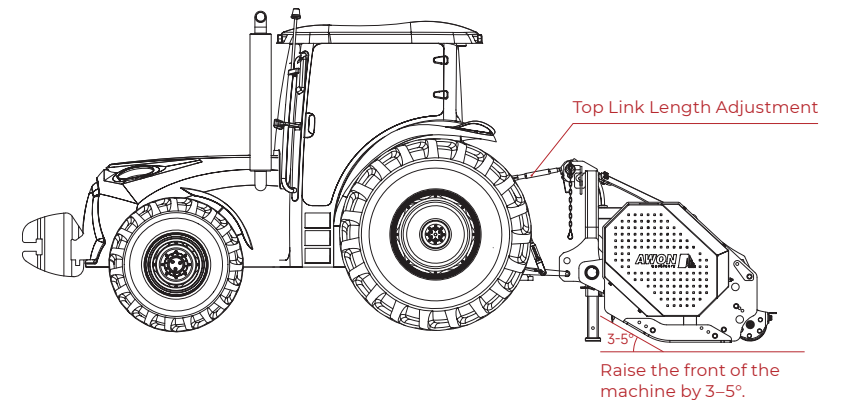

2.3 Driveline Adjustment

A. PTO Shaft Adjustment

The supplied PTO shaft has a standard length and may require adjustment depending on the tractor model.

The PTO shaft length adjustment procedure is as follows:

1. Connect the inner PTO shaft to the mulcher gearbox input shaft and the outer PTO shaft to the tractor PTO output shaft. Ensure that all connections are properly engaged and securely fastened without play.
2. The PTO shaft is equipped with safety chains. Attach the chains to both the mulcher and the tractor to prevent the PTO shaft guard from rotating.
3. Start the tractor and slowly raise and lower the mulcher to determine the maximum extension length of the driveline. The operating angle of the PTO shaft must not exceed 25° during operation. Measure and record the distance between the tractor PTO output shaft and the mulcher gearbox input shaft.

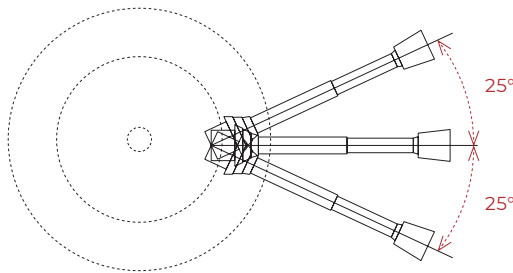

- ✓ The minimum overlap of the inner and outer tubes in the maximum extended position must not be less than one-third of the tube length and must be at least 15 cm (see Fig. 4).
- ✓ In the fully retracted position, a minimum clearance of 4 cm must be maintained between the inner and outer tubes (see Fig. 5).

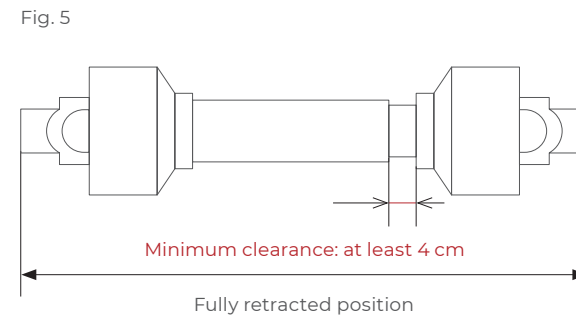
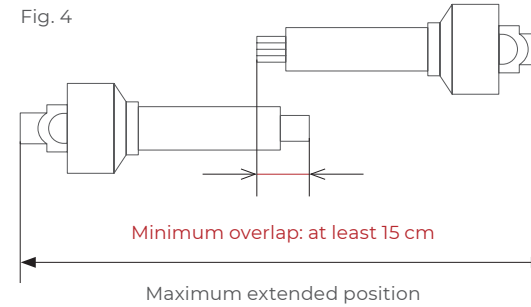

If the specified minimum overlap length and clearance cannot be achieved, the PTO shaft must be adjusted according to the following procedure:

- ✓ Shorten the inner and outer PTO shaft tubes by the same length (see Figs. 6 and 7). Remove burrs and smooth the cut edges (see Fig. 8). Then lubricate the inside of the outer tube and the outside of the inner tube (see Fig. 9). Ensure that the upper and lower shaft connections remain as parallel as possible.

- It is recommended to adjust the tractor linkage to ensure that the PTO shaft meets the operational requirements.

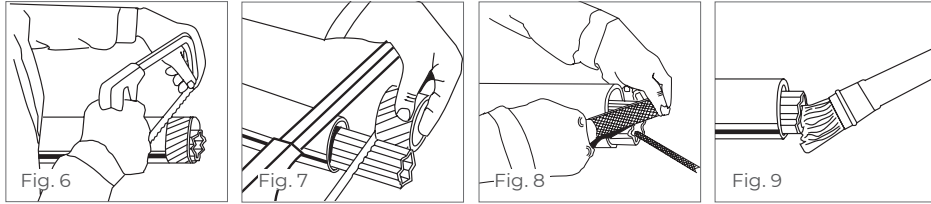

! When the machine is attached to a different tractor, the above inspection and adjustment procedures must be repeated.

B. Belt Tension Adjustment

The power is transmitted to the blade shaft through a belt, and the belt tension can be adjusted as required.

It is recommended to adjust the belt tension according to the following procedure:

- Remove the bolts securing the belt pulley cover (see Fig. 10) and open the cover.
- Check whether the belt tension meets the specified requirements (see Fig. 11).
- If the belt tension does not meet the requirement (see Fig. 11), adjust it by tightening the tensioning rod (Fig. 12 B) to increase the spring pressure until the correct tension is achieved.
- After the belt is properly tensioned, check that the belt lengths are consistent (Fig. 13).

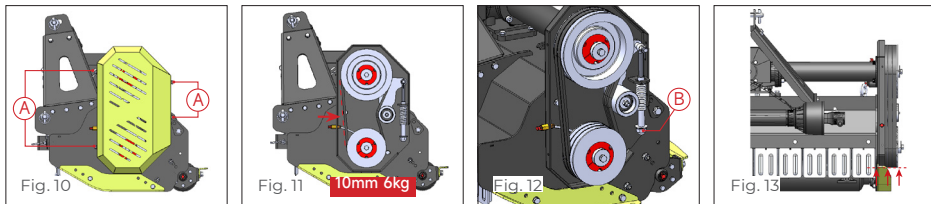

- The condition of the belts must be checked regularly to prevent excessive elongation due to wear, belt slippage, or other faults.
- To ensure proper power distribution, if any of the above issues occur, all belts must be replaced simultaneously.

2.4 Blade Operation

The rotor is one of the primary working components of the machine. Before operating the mulcher, inspect all blades for wear and ensure that all mounting bolts are properly tightened (see Fig. 14).



1. If a single blade is worn or damaged, it may be replaced individually.
2. If most blades on the rotor are severely worn, all blades must be replaced as a complete set to maintain rotor balance.
3. When replacing blades, original AWON replacement parts are recommended to ensure proper fit and dynamic balance.
4. After blade replacement, if noticeable vibration occurs during operation, the rotor must be checked for dynamic balance to prevent damage to bearings, gearbox, or structural components.
5. Dynamic balancing must be performed by an authorized service partner designated by the manufacturer.
6. If the rotor is subjected to a severe impact during operation, stop the machine immediately and inspect all rotating components before resuming work.

Fig. 14

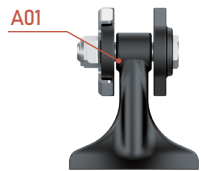
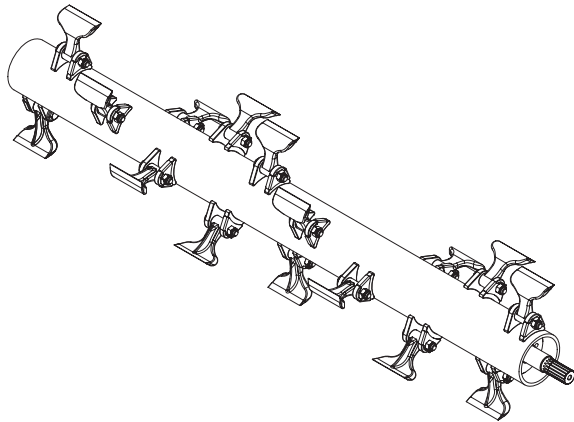

Hammer Blade



Y Blade

Bolt Tightening Torques (N.M)			
Bolt Grade	8.8	10.9	12.9
Fine Thread Bolts			
M8×1	26	36	44
M10×1.25	52	74	88
M12×1.25	91	127	153
M14×1.5	143	201	241
M16×1.5	214	301	361
M18×1.5	308	433	520
M20×1.5	431	606	727
M22×1.5	571	803	964
M24×2	731	1028	1234
M27×2	1070	1504	1806
M30×2	1480	2081	2498

Blade Wear

The following table specifies the permissible wear limits for the blades. Use these parameters to evaluate blade wear during inspection.



If any measured value exceeds the specified limit, the blade must be replaced immediately.

NOTICE

1. The wear of the mounting hole diameter (F) must not exceed 2 mm (see Fig. 15).
2. The wear of the blade length (L) must not exceed 5 mm (see Fig. 15).
3. The wear on one side of the bolt (T) and the bolt head (S) must not exceed 1 mm (see Fig. 15).

Fig. 15

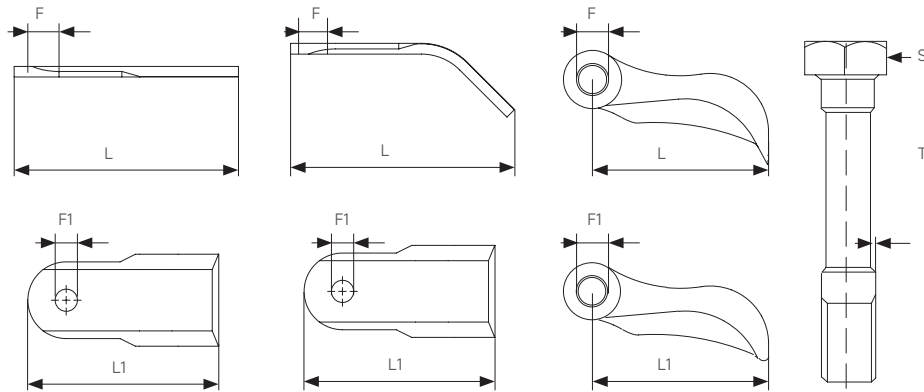

Model	FM100/120/240/160	FM165/185/205	FM180/200/220/240 FM260/280/300
Hole Diameter F (mm)	12.5	14.5	21
Hole Diameter F1 (mm)	14.5	16.5	23
Blade length L (mm)	80	100	100
Min blade length L1 (mm)	75	95	95
Bolt size S and T wear (mm)	1	1	1

Blade Replacement

1. If the blades are cracked or worn, they must be replaced. Select the appropriate blade type according to the application requirements (Hammer Blade or Y Blade).
2. When replacing the blades, pay attention to the direction of rotation. Install the blades according to the direction indicated in the diagram. (See Fig. 16)

Fig. 16

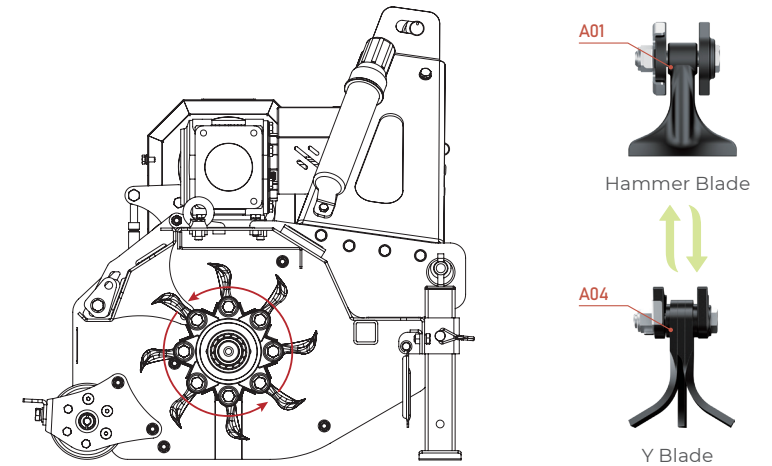

DANGER

Before performing any adjustment, inspection, or replacement:

1. Use the tractor hydraulic lifting system to slowly raise the mulcher until it is positioned 20–30 cm above the ground.
2. Securely support the machine with suitable rigid supports to prevent accidental lowering.
3. Disengage the PTO.
4. Ensure that the PTO shaft has completely stopped and cannot rotate. Failure to follow these instructions may result in serious injury or death.

2.5 Cutting Height Adjustment

Adjust the rear roller height to obtain the desired cutting depth.

Rear Roller Adjustment Procedure:

1. Loosen the four mounting bolts located at both ends of the rear roller (see Fig. 17).
2. Raise or lower both sides of the rear roller to the same height. Ensure symmetrical adjustment to maintain lateral balance.
3. Tighten the rear roller mounting bolts securely.
4. Slowly lower the mulcher to the ground and check the blade position. If the blades touch the ground, repeat steps 1–3 and readjust the rear roller height until the blades no longer contact the ground.
5. Adjust the skid plates on both sides accordingly. Loosen the fixing bolts at both ends, select the same adjustment position as the rear roller, and tighten the nuts securely after adjustment (see Fig. 17).

Fig. 17

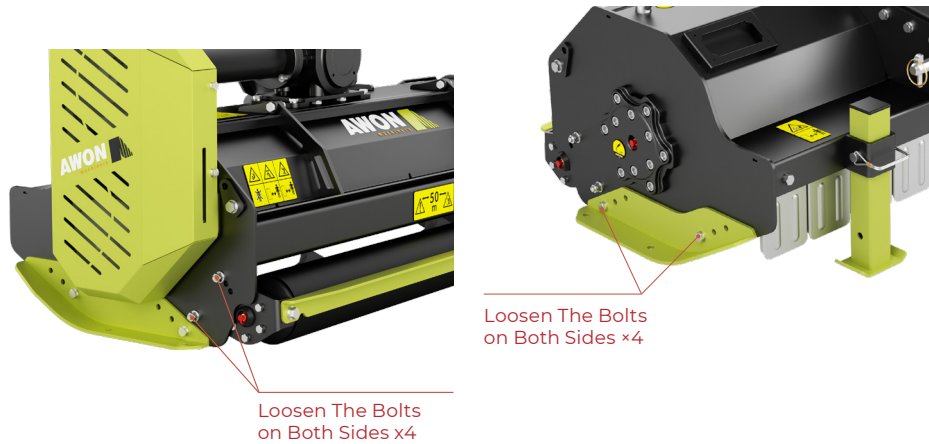

Restarting the Machine After Long-Term Storage

If the machine has been out of service for an extended period, the following procedures must be carried out before returning it to operation:



1. Check the gearbox oil level. If the oil level is below the specified minimum mark, refill with the recommended gear oil immediately.
2. Clean the area around the lubrication and oil filling points to prevent contamination. Apply grease to all designated lubrication points.
3. Check that all fasteners are properly tightened.
4. Inspect hydraulic couplings and hoses for oil leakage. If leakage is detected, tighten the connections. Replace damaged hoses or couplings if necessary.
5. Adjust the belt tensioning system to ensure correct belt tension before operation.

2.6 Mulching Operation

Before starting operation, ensure that no persons or animals are present in the working area. For safety reasons, maintain a safe distance between the operating range of the machine and nearby buildings, roads, or other structures (see Fig. 18).

Operate the machine at the rated PTO speed without load for several minutes to ensure that there are no abnormal noises or conditions that could affect normal operation.

Fig. 18

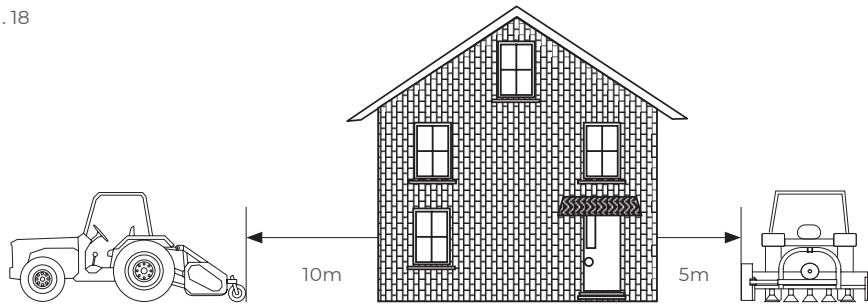

Recommendations During Operation



1. Avoid operating the machine in excessively wet or muddy conditions.
2. Do not exceed the rated PTO speed under any circumstances.
3. Avoid reversing (see Fig. 19) or performing S-shaped movements (see Fig. 20) during operation. When reversing or changing direction, raise the machine before maneuvering.
4. The recommended operating speed must not exceed 10 km/h. Excessive forward speed will reduce shredding quality.
5. To prevent impact damage between the machine and the ground, lower the machine slowly.
6. Before lifting the machine, ensure that the PTO is disengaged.

Fig. 19

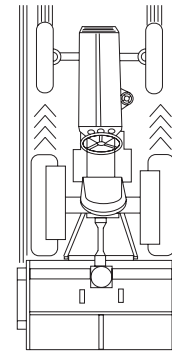
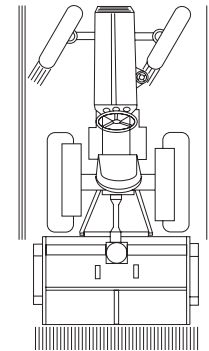

Fig. 20



If Abnormal Vibration Occurs

If abnormal vibration is detected during operation, stop the machine immediately and perform the following checks:



1. Check whether foreign objects are trapped in the blades or rotor.
2. Verify that all blades are correctly installed.
3. Inspect the blades for excessive wear.
4. Check whether the rotor shaft has been bent or deformed due to impact.

Recommended Operating Parameters

To improve machine service life and working efficiency, follow these recommendations:



1. Place the machine steadily on the ground. Gradually increase the PTO speed to the rated operating speed. Avoid sudden acceleration.
2. Adjust the cutting height appropriately. The cutting height should not be less than 3 cm above ground level. Soil contact is strictly prohibited (see Fig. 23).
3. Operating speed must not exceed 10 km/h (see Fig. 24). Exceeding this speed will significantly reduce machine service life.
4. To improve shredding quality, reduce forward speed.

Fig. 23

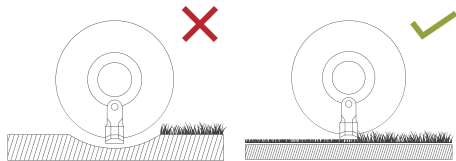
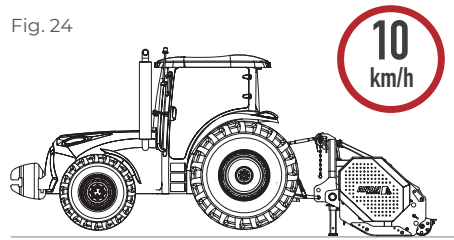

Fig. 24



3.1 Belt Replacement



V-belts are rubber components subject to aging and wear. Their service life depends on operating conditions and must be inspected regularly. Replace the belts when signs of wear, cracking, elongation, or slippage are detected.

Belt Replacement Procedure:

1. Remove the belt guard.
2. Loosen the tensioning rod to release the spring pressure, allowing the tension pulley and belts to become loose.
3. Use the appropriate service tool to remove the belts.
4. Install new belts and tighten the tensioning rod. Adjust the belt tension according to Section 2.3 "Belt Tension Adjustment".

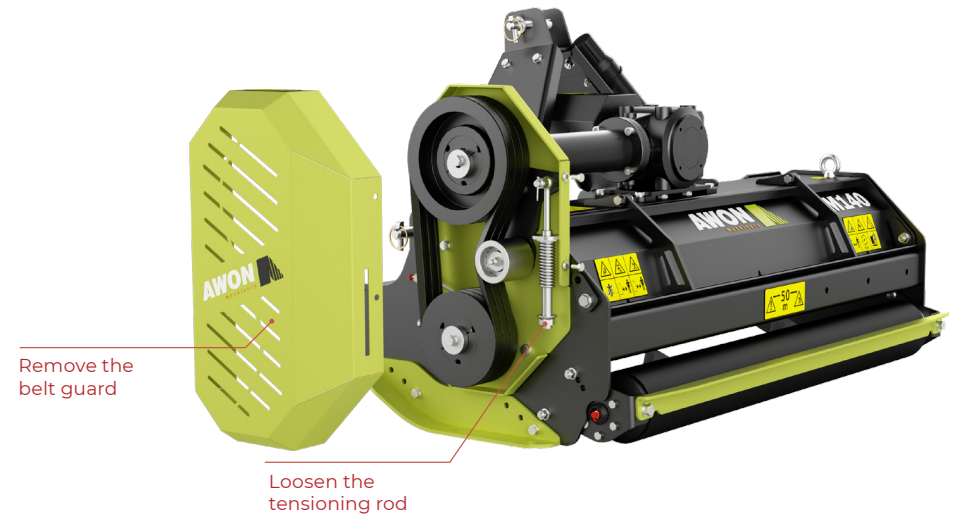

3.2 Troubleshooting

Problem	Possible Cause	Corrective Action
Belt failure	Improper belt tension	Adjust belt tension according to Section 2.3
	Worn or damaged belts	Replace belts as a complete set
Uncut strips or uneven cutting	Blades worn or cracked	Inspect and replace damaged blades
	Machine not level	Adjust three-point linkage to ensure the machine is level
Excessive vibration	Worn or damaged blades	Replace blades and check rotor balance
	Material wrapped around rotor or driveline	Remove foreign material from the transmission system
Excessive gearbox noise	Low gearbox oil level	Check and refill gearbox oil
	Bearing damage	Inspect and replace bearings if necessary
Slow hydraulic cylinder movement	Low tractor hydraulic oil level	Check and refill tractor hydraulic oil
	Hydraulic leakage	Tighten couplings or replace damaged hoses/components
Cutting too deep	Incorrect rear roller setting	Adjust rear roller height to increase cutting height

3.3 Routine Maintenance

Regular maintenance significantly extends the service life of the machine. The maintenance intervals specified in this manual are based on normal operating conditions. In extremely harsh, dusty, or humid environments, maintenance must be performed more frequently.

Maintenance Procedure



1. Ensure that lubricants meet the specified requirements. Recommended gearbox oil: ISO VG 220 + DIN 51517-3 (CLP).
2. Keep lubricants and grease out of reach of children. Avoid direct contact with skin.
3. Thoroughly clean the machine to remove grass residues, mud, and dust. Contamination may cause lubrication failure.
4. Inspect lubrication lines and fittings for leakage. Replace damaged components immediately.
5. When filling gearbox oil, do not exceed the overflow port. Maintain the oil level within the specified range.

End-of-Season or Long-Term Storage Procedure

After completing seasonal operation or before long-term storage, perform the following:



1. Park the mulcher on a level surface and ensure it is stable and properly supported.
2. Clean the interior of the mulcher thoroughly, including the rotor area and housing, removing all crop residues, dirt, and dust.
3. Tighten all loose bolts and nuts. Inspect blades for cracks or excessive wear and replace if necessary.
4. Loosen the belt tensioning system so that the belts remain in a relaxed position during storage.
5. Cover the machine with a waterproof protective cover and store it in a dry location.

4.1 Technical Specifications

Model	LIGHT				MEDIUM		
	FM100	FM120	FM140	FM160	FM165	FM185	FM205
Working width (mm)	1000	1200	1400	1600	1650	1850	2050
Transport width (mm)	1150	1350	1550	1750	1820	2020	2220
PTO speed (rpm)	540				540		
Output (hp)	25-40	25-40	30-50	30-50	50-70		
Output (kW)	18-30	18-30	22-37	22-37	37-52		
Drive belts	3				3		
Weight (kg)	205	228	252	264	440	496	502
Mounting position	Rear				Rear		
3-point hitch type	Cat. I				Cat. I / II		
Counterblade	1				1		
Cutting diameter (mm)	< 40				< 60		
Rotor diameter (mm)	108				127		
Hammer blades (pcs / kg)	18 / 0,34	20 / 0,34	24 / 0,34	26 / 0,34	22 / 0,81	24 / 0,81	26 / 0,81
Y-blades (pcs / kg)	54 / 0,46	60 / 0,46	72 / 0,46	78 / 0,46	66 / 0,86	72 / 0,86	78 / 0,86

Product Features	FM100	FM120	FM140	FM160	FM165	FM185	FM205
Openable rear cover	•	•	•	•	•	•	•
Automatic belt tensioning system	•	•	•	•	•	•	•
Rear roller scraper	•	•	•	•	•	•	•
Hammer (T) or Y-blades	T/Y	T/Y	T/Y	T/Y	T/Y	T/Y	T/Y
Adjustable side skids	•	•	•	•	•	•	•
Free wheel clutch	•	•	•	•	•	•	•

Optional parts	FM100	FM120	FM140	FM160	FM165	FM185	FM205
SD550	•	•	•	•	•	•	•
HD550	•	•	•	•	•	•	•
OTKL	•	•	•	•	n/a	n/a	n/a
OTK	n/a	n/a	n/a	n/a	•	•	•

HEAVY				MAX		
FM180	FM200	FM220	FM240	FM260	FM280	FM300
1800	2000	2200	2400	2600	2800	3000
2000	2200	2400	2600	2850	3050	3250
540				540		
70-100				90-120		
52-75				67-89		
4				5		
599	633	670	800	872	906	1026
Rear				Rear		
Cat. II				Cat. II / III		
1				2		
< 80				< 100		
168				220		
18 / 1,67	20 / 1,67	22 / 1,67	24 / 1,67	24 / 1,67	26 / 1,67	28 / 1,67
n/a				n/a		

FM180	FM200	FM220	FM240	FM260	FM280	FM300
•	•	•	•	hydraulic	hydraulic	hydraulic
•	•	•	•	•	•	•
•	•	•	•	•	•	•
T	T	T	T	T	T	T
•	•	•	•	•	•	•
•	•	•	•	•	•	•

FM180	FM200	FM220	FM240	FM260	FM280	FM300
•	•	•	•	n/a	n/a	n/a
•	•	•	•	n/a	n/a	n/a
n/a	n/a	n/a	n/a	n/a	n/a	n/a
n/a	n/a	n/a	n/a	n/a	n/a	n/a

4.2 PTO Selection Table

A 1 1/8"-Z6			
B 1 3/8"-Z6			
C 1 3/4"-Z6			
D 1 3/8"-Z21			
E 1 3/4"-Z20			
F 8x42x48x8			
G 8x32x38x6			

4.3 Three-point Linkage Specifications

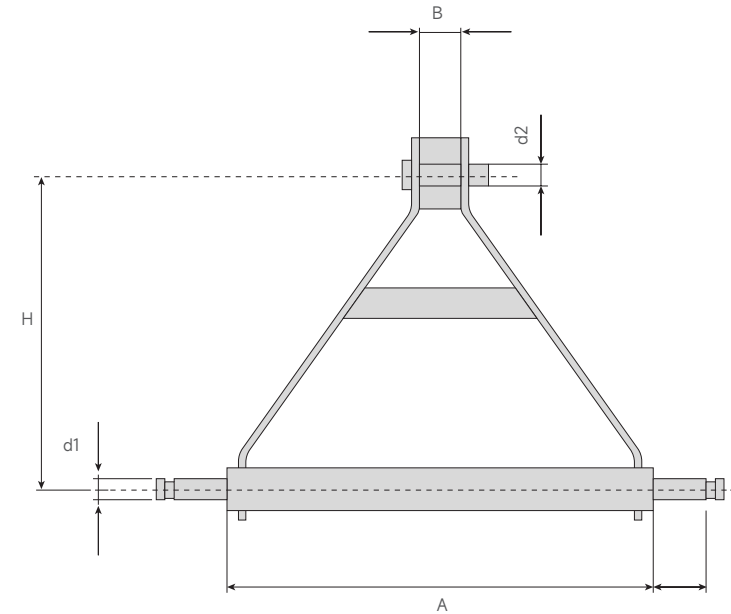

Parameter	Category I	Category II	Category III
Tractor Power	≤ 48 kW	30–92 kW	60–185 kW
Top Link			
Top Link Pin Diameter (d2)	19 mm	25.5 mm	31.75 mm
Minimum Frame Inner Width (B)	52 mm	52 mm	52 mm
Lower Link			
Lower Link Span (A)	683 mm	825 mm	965 mm
Lower Link Pin Diameter (d1)	22 mm	28 mm	36.6 mm
Vertical Height (H)	460 mm	610 mm	685 mm
Minimum Pin Offset (C)	49 mm	49 mm	52 mm



AWON Machinery

Professor Lorentzweg 16
5144 NP Waalwijk
The Netherlands

+31 (0)416 – 745 338

info@awonmachinery.com
www.awonmachinery.com